

GLC Coupé



Mercedes-Benz



More than an SUV.
More than a coupé.
More than ever before.

Some personalities immediately make their mark. With their appearance. Their self-assurance. And their unique character. Much like the new GLC Coupé, which combines the merits of an SUV and a coupé like no other. In a style all of its own. More dynamic and sportier than ever.





Because communication is everything today.

The new GLC Coupé doesn't just listen to what you say, it also responds immediately to your touches and gestures – courtesy of MBUX, the sophisticated Mercedes-Benz User Experience with a wealth of new control and display features. Like the large media display with touch function or the fully digital instrument cluster with navigation display.



Something special.
On every trip, from any angle.

More sporty than ever, the new GLC Coupé really catches the eye. With wider aprons, new tailpipe trims, and LED High Performance headlamps sporting a cutting-edge light design fitted as standard for the first time. The optional AMG Line and a host of new wheel designs take its unique sporty and elegant character to the highest level.

The image shows the front interior of a Mercedes-AMG vehicle. The seats are black leather with yellow stitching and yellow accents on the side bolsters. The center console has a silver AMG logo. The steering wheel is black with silver accents. The dashboard and door panels are black with silver trim. The view through the windows shows a cloudy sky.

Take a seat and
enjoy the view.

An exceptionally sporty and refined interior welcomes you on board. Large displays, smooth transitions and the finest new upholstery let you experience modern luxury with all the senses.

The rear end: the start of something new.

The new GLC Coupé's rear end is eye-catchingly athletic and sporty. Powerful contours combine here with sensual, pure lines to dynamic effect. The impressive apron, the stylish chrome elements and the tailpipe trims integrated in the bumper all stand out here. The slender LED tail lights with cutting-edge light design are particularly striking.



Sit in an SUV.
Drive a sports coupé.

Every metre and every second become a sporting event in the new GLC Coupé. You can make it even more agile with the optional DYNAMIC BODY CONTROL suspension, which lets you individualise the vehicle's damping and handling characteristics. At the touch of a button, for a noticeably more comfortable or more dynamic driving experience. Three options are available for this: "Comfort", "Sport" and "Sport+".





Energising comfort and exemplary safety.

During rush hour, on long drives at night, or on unfamiliar routes – your new GLC Coupé noticeably takes the strain out of driving, particularly in stressful situations. It’s all down to a concept that makes every journey in a Mercedes-Benz a safer and unique experience: Mercedes-Benz Intelligent Drive. Because the time you spend behind the wheel is your time. Time for relaxation. Time to replenish your energy. So that, first and foremost, you reach your destination safely, but are also relaxed when you get there.



EQUIPMENT HIGHLIGHTS – DRIVING ASSISTANCE SYSTEMS

Driving Assistance package. Hit the road to autonomous driving: state-of-the-art systems assist you in many situations: adjusting the speed, steering and even when there is a risk of a collision. The risk of an accident is reduced – passengers and road users are protected effectively. This way you are able to reach your destination relaxed and safe.

The innovative **PRE-SAFE® Sound** system generates a sound signal through the loudspeakers that can trigger a protective reflex: your auditory system briefly disconnects, thereby protecting itself from the loud noise of a crash.

Parking package with 360° camera. Almost like having a valet on board. Active Parking Assist with 360° camera makes it easier for you to find a parking space and to manoeuvre into and out of parking spaces. Here the choice is yours: park with ease yourself thanks to all-round visibility – or make things even easier still by getting the car to park for you.



Mercedes-Benz User Experience.

In the new GLC Coupé, you can now control almost everything as intuitively as you do on your smartphone. Simply by using the large touchscreen, the new touchpad, or the Touch Control buttons on the new steering wheel. One touch is all it takes to adjust the display style, the ambient lighting, or the infotainment to meet your needs.



EQUIPMENT HIGHLIGHTS – CONTROL AND DISPLAY CONVENIENCE

With the **MBUX voice control** option, the new GLC Coupé not only listens to you, it hangs on your every word and talks to you. You can converse with your car in a perfectly natural manner to adjust and control virtually all the functions in the car. Simply say “Hey Mercedes”, and the new GLC Coupé will be all ears.



Fully digital instrument cluster.

The fully digital instrument display with the display styles “Classic”, “Progressive” and “Sporty” enables you to decide which information is important to you and in which way you wish to have it displayed. The 31.2 cm (12.3-inch) display delivers a pin-sharp image which is very easy to read in all light conditions.



Burmester® surround sound system.

With the optional Burmester® surround sound system your new GLC Coupé becomes a concert hall. 13 high-performance speakers, a 9-channel DSP amplifier, a total system output of 590 W, and electronic and acoustic elements tailored precisely to the interior conjure up a unique sound. The surround function and the sound optimisation for the front and rear seats provide an even more intensive listening experience.



MULTIBEAM LED headlamps.

Perfect visibility for you: the adaptive MULTIBEAM LED headlamps have individually controllable LEDs that react to the traffic situation. Partial main beam shines past other road users without dazzling them. ULTRA RANGE main beam increases the range to the permitted maximum. The Active Light System and cornering lights further optimise illumination of the way ahead.



Sporty wheel design.

There's no stopping the new GLC Coupé – it is forever evolving. An even broader range of exclusive wheels is now available, offering a host of new rim designs. From 45.7 cm (18 inches) to 50.8 cm (20 inches), from elegant to sporty: the choice is yours.

The AMG Line.

The expressive AMG Line styling lends the exterior a sporty, exclusive touch – your clear statement for powerful design. On top of this, the technical features give palpably more fun at the wheel, since the agile configuration of the sports suspension with Sports Direct-Steer makes the handling noticeably dynamic.



The Night package.

The Night package adds attractive touches: many of the exterior features are finished in black. They underscore the sporty character and special individuality of your vehicle, enabling you to demonstrate your sense of expressive design and exclusive sportiness.





DYNAMIC BODY CONTROL.

With the optional DYNAMIC BODY CONTROL suspension you can adapt the new GLC Coupé's damping and handling characteristics to your individual needs. At touch of a button, for a noticeably more comfortable or more dynamic driving experience. Three options are available for this: "Comfort", "Sport" and "Sport+". According to whether you are looking for particularly comfortable, sporty or extra sporty handling. The damping is continuously variable and is adjusted individually for each wheel. For even better driving safety and ride comfort.



4MATIC all-wheel drive.

On tarmac or light off-road terrain: 4MATIC lets the new GLC Coupé show its impressive strength in adverse weather conditions such as rain, black ice or snow. Thanks to the interplay between the individual wheels, the permanent all-wheel drive is able to ensure exemplary driving stability and traction at all times. For greater dynamism, comfort and safety overall.

Technical data.

	Petrol engines			
	GLC 200 4MATIC	GLC 300 4MATIC	AMG GLC 43 4MATIC	AMG GLC 63 S 4MATIC+
Displacement (cc)	1,991	1,991	2,996	3,982
Rated output* (kW [hp] at rpm)	145 [197]/5,500-6,100	190 [258]/5,800-6,100	287 [390]/5,500-6,000	375 [510]/5,500-6,250
Acceleration from 0 to 100 km/h (s)	7.9	6.2	4.9	3.8
Top speed (km/h)	215	240	250	280

Dimensions.

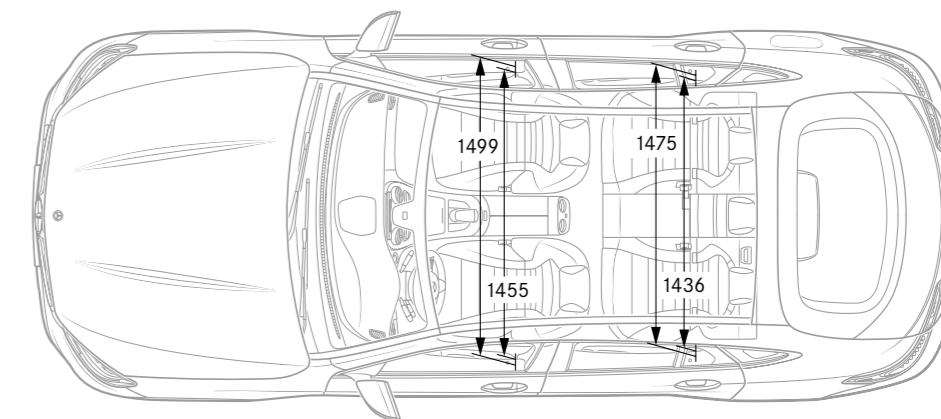
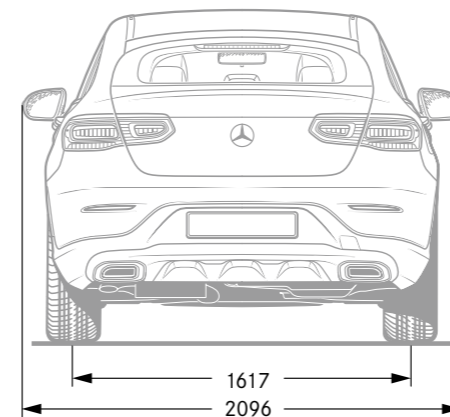
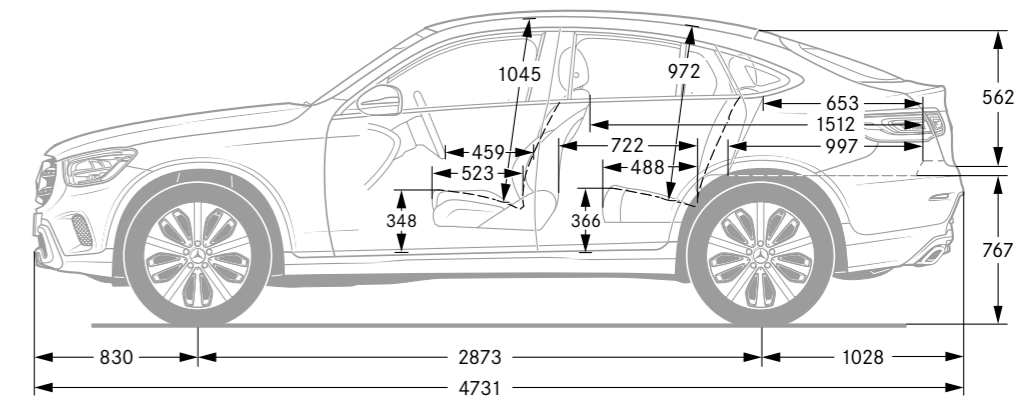
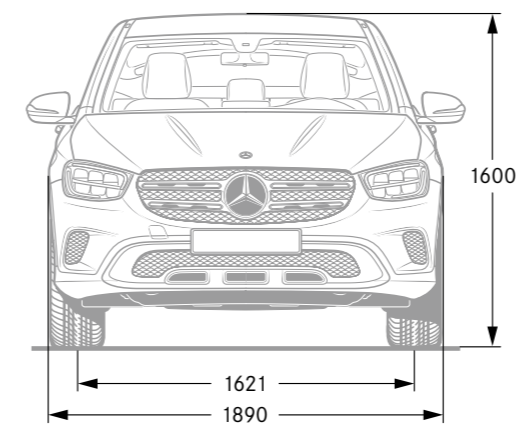

The best for the engine:
Mercedes-Benz genuine engine oils.

All figures in millimetres. The illustrated dimensions are mean values. They are valid for vehicles in basic specification and in unladen condition.



SPORT — F O R — GOOD

Mercedes-Benz is one of the founding partners of the worldwide “Laureus Sport for Good Foundation”, which was established in 2000. It is the Mercedes-Benz brand’s most important social initiative. Laureus Sport for Good supports children and young people in need through social sports projects, opening up new perspectives and imparting important values such as team spirit, respect and determination. “Change the Game for Kids” is our mission statement which we wish to share with you. In buying a Mercedes-Benz you are supporting the “Laureus Sport for Good” movement.

Please note: changes may have been made to the product since the editorial deadline (28.02.2019). The manufacturer reserves the right to make changes to the design, form, colour and the product specification during the delivery period, provided these changes, while taking into account the interests of the vendor, can be deemed reasonable with respect to the purchaser. Where the seller or the manufacturer uses symbols or numbers to describe an order or the subject of an order, no rights may be derived solely from these. The illustrations may show accessories and items of optional

equipment which are not part of standard specification. This publication is distributed internationally. However, information regarding statutory regulations, legal requirements and taxation and the consequences thereof applies to the Federal Republic of Germany only and is correct at the time of the editorial deadline. For current and more specific information, please contact your nearest authorised Mercedes-Benz sales partner.

www.mercedes-benz.com